

FMC05系列 压电机控制器

FMC05 Series Piezo Motor Controller

FMC05-01 FMC05-03



- 免费标准版SDK
Window、Linux环境下支持多种开发语言:C/C++、C#、Matlab、LabVIEW等

产品简介 OVERVIEW

压电机控制器采用驱控一体系统对压电位移台进行全闭环控制。菲克提供功能丰富的配套软件对位移台进行控制。也可以通过我们提供的标准SDK或通讯协议进行二次编程开发,进行位移台控制。

The piezo motor controller use integrated drive-control system to perform full closed-loop control of the piezo motor stage. Feinixs provides feature-rich supporting software to control the displacement stage. You can also carry out secondary programming development through the standard SDK or communication protocol provided by us, and then control the displacement stage.

产品参数 SPECIFICATIONS

Model	FMC05-01/03
电机类型 Motor Type	Piezo Motor
轴数 Axes	01/03
控制环(开/闭) Loops(Open/Close)	Closed Loops
运动功能 Function of Motion	P to P,Homed Relative Move ABS Move
脉冲频率 Pulse Frequency	2M
触摸屏 HMI	/
手轮 Hand Wheel	/
通讯接口 Communication Port	RS485

产品特点 ADVANTAGE

FMC05-01/03

- 结构精致小巧
- 内置高性能压电电机驱动器,支持菲克全系列压电产品
- 全闭环控制
- 多种运动模式选择:点动、相对运动、绝对运动,往返运动
- 任意位置坐标清零
- 提供标准控制软件,即开即用

面板示意图 PANEL

FMC05-01

前面板



控制器开关

通讯接口

后面板



电机接口

电源插头

FMC05-03

前面板



通讯接口

产品型号

控制器开关

后面板



电机接口

电源插头

FMC05系列
压电机控制器

FMC05 Series Piezo Motor Controller

FMC05-01 FMC05-03



配套软件 SOFTWARE

FMC05系列控制器均配有菲克科技独立开发的控制软件,可以通过PC上位机安装使用。软件基本功能齐全,设置简单,适合绝大多数客户使用。



FMC05-01软件界面示意图

配套产品 RELATED PRODUCTS



产品图纸 DIMENSIONS

FMC05-01

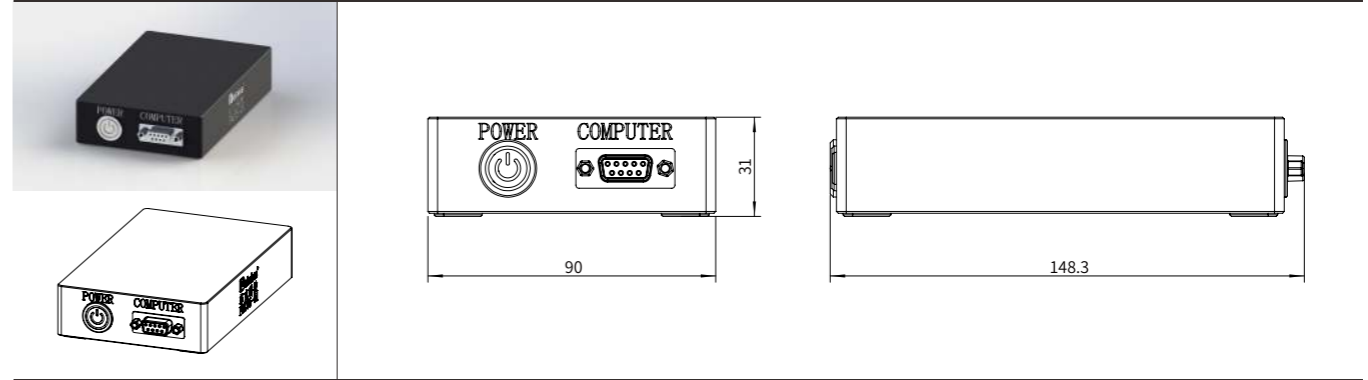

FMC05-03

